

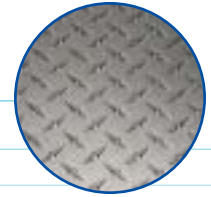

EGA/EGHV Touch-Up Spray Gun

# EGA

Touch-Up  
Conventional  
Spray Gun



# EGHV

Touch-Up  
Maximum Performer  
HVLP Spray Gun

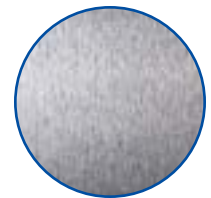
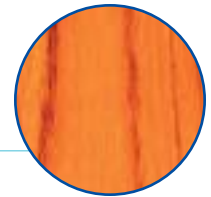

The gun of choice for touch-up, shading, edging and detail decorating, EGA/EGHV touch-up guns provide precise control for any type of delicate spray finishing applications. The guns feature a forefinger trigger to enhance operator control, and a long needle taper to make detail work easy.

- Equipped with stainless steel tip and needle
- Knurled knobs allow fine spray adjustments for fluid and pattern control
- Fluid delivery by attached suction feed or remote pressure feed cup
- Ideal for hours of fatigue-free precision painting

## Ordering Information

The EGA/EGHV touch-up gun is available with the following air cap and fluid tip set-up, factory-assembled for immediate delivery.

### Part No.

EGA-503-390F  
EGHV-531-397E

EGA/EGHV Touch-Up Spray Gun

## EGA/EGHV Accessories

- 8 oz. Cup (TGS-503) – Solvent-resistant polyethylene cup available
- Remote Cups – Two-quart remote cups are available in aluminum (KB-555) or stainless steel (KB-545-SS)
- Additional Accessories – Hose assemblies, air cap test kit, gun and hose cleaning equipment and other accessories also are available

## Technical Specifications – EGA

Body:	Drop forged aluminum
Weight:	7 oz. (196 gr) with air cap and ring
Air and Fluid Inlet:	1/4" NPS(M)
Wetted Parts:	Aluminum Body 400-grade stainless steel Tip and Needle
Air Consumption:	3 CFM @ 30 psi
Service Bulletin:	SB-2-163

## Technical Specifications – EGHV

Body:	Drop forged aluminum
Weight:	7.5 oz (210 gr)
Air and Fluid Inlet:	1/4" NPS(M)
Wetted Parts:	Stainless Steel
Air Consumption:	8.8 CFM @ 10 psi cap pressure
Air Cap Pressure:	10 psi @ 50 psi inlet
Service Bulletin:	SB-2-167

# EGA/EGHV Touch-Up Spray Gun

EGA (Conventional)

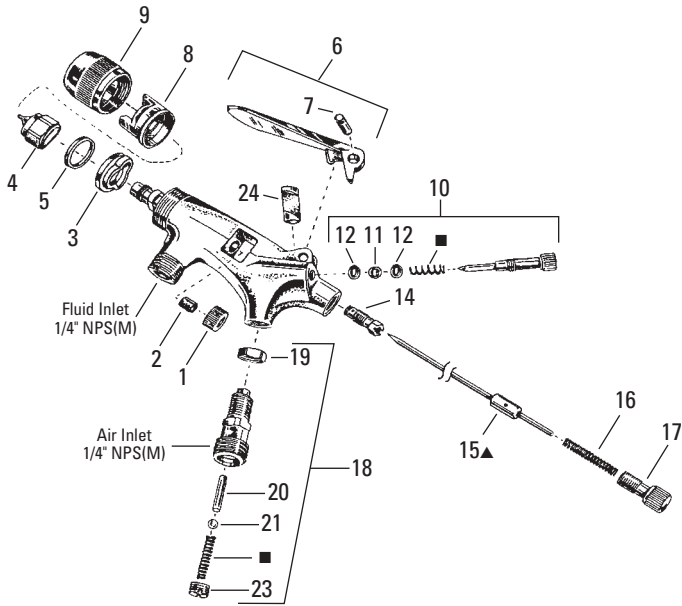

EGHV (HVLP)

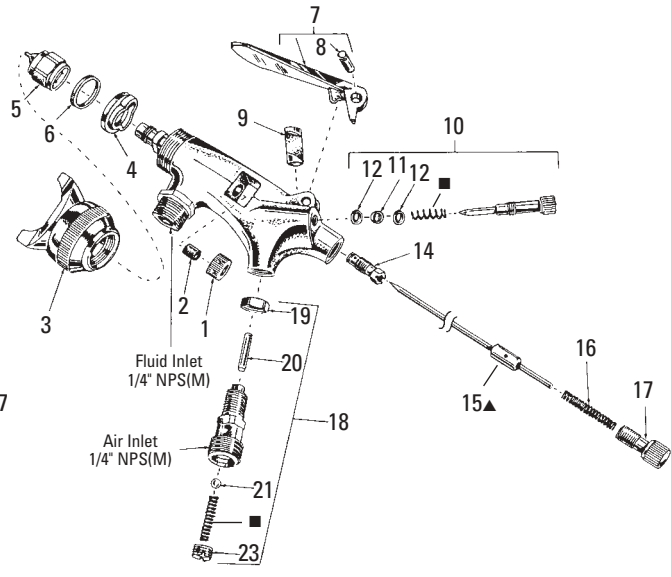

Customer Service 1.800.992.4657

EGA (Conventional)

Ref. No.	Model No.	Description	Ind. Parts Required
1	EGA-4	Packing Nut	1
■ 2	38273-136-K5	Fluid Needle Packing (Kit of 5)	1
3	EGA-7	Baffle	1
4	EGA-4000-F	Tip, Needle and Gasket (lapped) (includes 4, 5, 15)	1
■ 5	EGA-59-K5	Gasket (Kit of 5)	1
6	EGA-443	Trigger and Stud Assy.	1
■ 7	AG-3-1-K5	Trigger Bearing Stud (Kit of 5)	1
8	EGA-40-390	Air Cap	1
9	EGA-11	Retaining Ring	1
10	EGA-454	Fan Adjusting Assembly	1
■ 11	SSG-8205-K10	O-Ring (Kit of 10)	1
■ 12	AG-26-K10	Washer (Kit of 10)	2
14	EGA-3	Packing Gland	1
■ 16	AG-7-K5	Needle Spring Kit (Kit of 5)	1
17	AG-16	Fluid Needle Adjusting Screw	1
18	EGA-441	Air Valve Assy.	1
19	AG-46-K3	Lock Nut (Kit of 3)	1
■ 20	EGA-9-K5	Stem (Kit of 5)	1
■ 21	SST-3008-K5	Ball (Kit of 5)	1
23	GD-36-K5	Spring Retainer (Kit of 5)	1
■ 24	EGA-5-K6	Air Valve Plunger (Kit of 6)	1

■ A quantity of necessary parts is included in Gun Repair Kit KK-5044. Suffixes -K3, -K5, etc. designates kits of multiple parts. Example 38273-136-K5 is a kit of (5) packings.

EGHV (HVLP)

Ref. No.	Model No.	Description	Ind. Parts Required
1	EGA-4	Packing Nut	1
■ 2	38273-136-K5	Needle Packing (Kit of 5)	1
3	EGHV-439-397HV	Air Cap with Ring	1
4	EGA-7	Baffle (air distributor)	1
5	EGA-4000-E	Tip, Needle and Gasket Assy. (lapped) (includes 5, 6, 15)	1
6	EGA-59-K5	Gasket (Kit of 5) (Polyethylene)	1
7	EGA-443	Trigger and Stud Assy.	1
■ 8	AG-3-1-K5	Trigger Bearing Stud (Kit of 5)	1
■ 9	EGA-5-K6	Air Valve Plunger (Kit of 6)	1
10	EGA-454	Fan Adjustment Assy. - Horn	1
■ 11	SSG-8205-K10	O-Ring (Kit of 10)	1
■ 12	AG-26-K10	Washer (Kit of 10)	2
14	EGA-3	Packing Gland	1
■ 16	AG-7-K5	Needle Spring (Kit of 5)	1
17	AG-16	Needle Adj. Screw	1
18	EGA-441	Air Valve Assy.	1
19	AG-46-K3	Lock Nut (Kit of 3)	1
■ 20	EGA-9-K5	Stem (Kit of 5)	1
■ 21	SST-3008-K5	Ball (Kit of 5)	1
23	GD-36-K5	Spring Retainer (Kit of 5)	1
24	EGHV-3	Fluid Adapter	1

■ A necessary quantity of parts is included in Gun Repair Kit KK-5044. Suffixes -K3, -K5, etc. designates kits of multiple parts. Example: EGA-59-K5 is a kit of (5) seals.

## Air Cap Selection Guide

Model	Typical Materials	Air Cap Model No.	Air Cap Part No.	Air Consumption @ 70°F		Typical Pattern Size in. (mm)	Fluid Tip No. and Size in. (mm)	Type of Feed ▶
				PSI	SCFM			
EGA (Conventional)	Detail, Touch-Up, Stains, Lacquer	390	EGA-40-390 ▲	30	3	Up to 3" (75)	F .042" (1.1)	P, S
EGHV (HVLP)	Detail, Touch-Up, Enamels, Lacquer	#397HV	EGHV-439-397HV	10	8.8	Up to 6" (150)	E .070" (1.8)	P, S

▶ Type of Feed Reference:  
P = Pressure  
S = Suction

▲ Retaining Ring Required: Part No. EGA-11

## Air Cap Test Kit

KK-5043 Air Cap Test Kit – Includes air cap and gauge, for use with #397HV air caps only.

## Fluid Tips & Needles

Model	# on Fluid Tip	Order Tip and Needle Set
EGA (Conventional)	F	EGA-4000-F
EGHV (HVLP)	E	EGA-4000-E



World Headquarters  
Industrial Finishing  
Devilbiss  
195 Internationale Blvd.  
Glendale Heights, IL 60139  
630-237-5000  
Fax 630-237-5011  
www.devilbiss.com

